

# Spice Application Systems Ltd

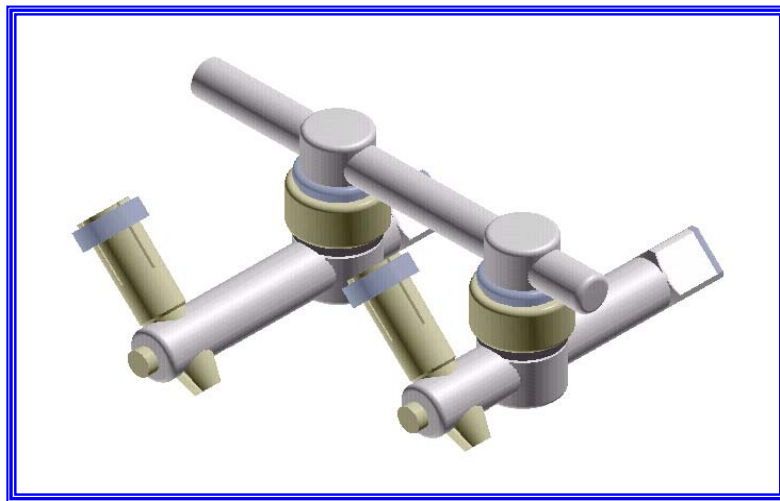

INSTRUCTION MANUAL  
**ELECTROSTATIC FOOD SPRAY UNIT  
MODEL SAS O**

PO Box1190  
Oxford  
OX4 4GH  
England, UK

Tel:- 00 44 79 67 63 85 25  
Fax:- 00 44 87 01 60 27 55  
E-mail:- [info@spiceapplications.com](mailto:info@spiceapplications.com)  
Web:- [www.spiceapplications.com](http://www.spiceapplications.com)

# INDEX

EC DECLARATION OF CONFORMITY FOR MACHINERY .....	3
WARNINGS .....	4
SAFETY GUIDELINES .....	4
TECHNICAL FEATURES .....	5
ELECTRICAL CONTROL UNIT .....	6
ELECTROSTATIC GENERATING HEAD .....	6
PNEUMATIC CONTROL UNIT .....	6
CONTROL UNIT FRONT PANEL.....	7
CONTROL UNIT REAR PANEL.....	7
MANIFOLD INLET ASSEMBLY .....	8
CONTROL GENERAL ASSEMBLY- FRONT.....	9
CONTROL GENERAL ASSEMBLY- REAR.....	10
CONTROL DIMENSIONS.....	11
CONTROL GENERAL ASSEMBLY- PART NUMBERS .....	12
MANIFOLD INLET ASSEMBLY- PART NUMBERS .....	12
ELECTROSTATIC GENERATING HEAD - DRAWING.....	13
MAINS POWER WIRING.....	14
OPERATING PRINCIPLE .....	14
INSTALLATION .....	15
ATOMIZATION .....	16
OIL FLOW SYSTEM.....	16
START UP .....	17
QUALITY ADJUSTMENT .....	17
CLEANING .....	18
CLEANING PROCEDURE.....	18
SERVICING .....	19
SHUTTING DOWN .....	19
DAILY CARE .....	19
TROUBLE SHOOTING .....	20
AIR KNIFE PARTS.....	21
STATIC ELECTRICITY TESTER.....	22
REMOTE TRIGGER WIRING DIAGRAM .....	23
SYSTEM PICTURE.....	24
AIR FILTER .....	25

Dear Customer,

Thank you for buying a new ELECTROSTATIC FOOD SPRAY UNIT - model SAS/ OIL. Every care has been taken, from design to manufacture, to ensure that this product gives you complete satisfaction.

To obtain the best performance and reliability from this equipment it is strongly recommended to read the instruction manual thoroughly before attempting to use the equipment.

#### **EC DECLARATION OF CONFORMITY FOR MACHINERY**

The manufacturer :           Spice Application Systems Ltd.,  
  PO Box 1190, Oxford, OX4 4GH, England, UK.  
  Tel: 00 44 11 79 10 23 93  
  Fax: 00 44 87 01 60 27 55

Herewith declares that "the Electrostatic Food Spray Unit", is in conformity with the provisions of :

EC Machinery Directive 89/392/EEC Annex II, sub A  
EC Low Voltage Directive 73/23/EEC  
EC Directive of Electromagnetic Compatibility 89/336/EEC:  
  EN 50081-1  
  EN 50082-1  
EC Equipment Using Flammable Materials 89/336/EEC  
  EN50 050:1986  
  EN50 053:Part 2:1989

All as amended, and with national implementing legislation.

Established in Oxford, on October 1st 1999

Peter King  
Managing Director

## Warning

All controls within the Control Box have been adjusted for optimum performance and safety during manufacturing.

The Electrostatic Generating head is sealed for IP 65.

Re-adjustments, alterations or substitutions of any component may result in a hazardous operating condition a failure and possible damage to the equipment as well as over-riding the built in safety features.

Any unauthorized modification will invalidate the warranty and could endanger the work force.

Under no circumstances are any alterations allowed to the electrostatic equipment without specific written instructions and consent from Spice Application Systems Ltd.,

### SAFETY GUIDELINES

- ➔ The person in charge of the Manufacturing work area should ensure that personnel are properly trained in the use of this equipment. The safety rules which follow should be fully understood and applied at all times.
- ➔ Never point the spray unit at any person or animal.
- ➔ Spraying certain products can be dangerous, depending on what is being sprayed so full protection for operators in the form of instructions supplied with that product must be adhered to at all times.
- ➔ The normal safety rules and precautions for powder/liquid atomisation must be observed.
- ➔ For more information, consult the local safety rules. In addition, the following precautions must be observed.
- ➔ **WARNING ! Failure to observe one of the following rules may affect the operation of the equipment and create unsafe conditions.**

**ALL personnel who are associated with the coating operation should read and fully understand this manual. It is especially important that the operators of the electrostatic equipment and their supervisory personnel understand the requirements for safe and proper usage of the electrostatic process.**

## TECHNICAL FEATURES

The SAS OIL spray unit uses the principle of atomising the oil as it is pumped through the spray nozzle. The oil becomes atomised and passes through an electrostatic field, it is able to obtain the ultimate wrap-around effect, onto a grounded product.

An electronic safety device, incorporated into the SAS power supply unit, automatically detects the presence of a grounded object in the vicinity of the spray head. Once this ground approaches within 10 cm / 4" this device reduces the voltage.

### Pressure/Connections :

Control air out ..... polyamide hose Ø 6 x 8mm  
Control air in..... polyamide hose Ø 8 x 10mm

**The pneumatic system to provide clean, dry, oil free food quality compressed air a minimum pressure of 4 bar / 58 psi**

### Electrical features

Ionization..... Negative charge on the electrode.

**Weight :** Total weight with BG (without cable or hose) : Around 1 kg 250 / 2.75 lb

**Stainless Steel** Food Quality 316/304

**Plastics** Polypropylene Co Polymer-Nat

Acetal Co Polymer-White

**Cable** Polyurethane-Black

**Cable Gland** Polymide-Light Grey

## **ELECTRICAL - CONTROL UNIT**

Mains Electrical Supply	- Single Phase 3 Wire (Live-Neutral-Earth)
Supply Voltage	- 90 – 264V a.c.
Supply Frequency	- 47 – 64 Hz
Connected Load	- 40 VA
Circuit Protection	- 0.6 A Miniature Circuit Breakers – Live & Neutral
No. of Outputs to Applicators	- 1 or 2 Applicators
Output Voltage to Applicators	- 3.5 – 13V d.c.
Output Current to Applicators	- 400mA Max
Protection Category	- IP 54 (IP 67 when fitted into an SAS designed cabinet)
Operating Temperature	- -10°C/+60°C

## **ELECTROSTATIC GENERATING HEAD**

Supply Voltage	- 3.5 – 13V dc
Supply Current	- 400mA Max
Output Voltage	- 20-85kV
Output Current	- 50uA Max
Protection Category	- 1P 67
Operating Temperatures	- -10°C/+60°C

## **PNEUMATIC – CONTROL UNIT**

Compressed Air Supply	- 8 Bar (114psi) Max / 5 Bar (75 psi) Min
Compressed Air Consumption	- 10m <sup>3</sup> /hr (6 c.f.m) per Applicator
Max Water Vapour Content	- 1.3g/m <sup>3</sup>
Max Oil Vapour Content	- 0.1 p.p.m.
Regulated Air Output	- 0-4 Bar

## CONTROL UNIT FRONT PANEL

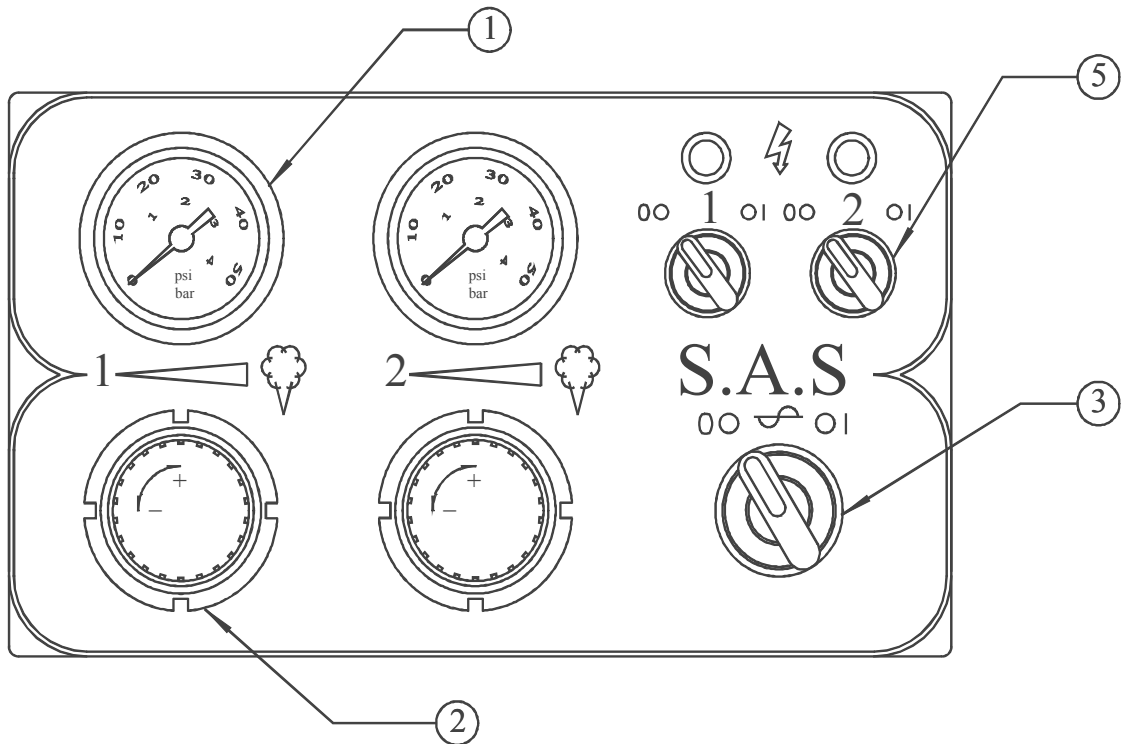

## CONTROL UNIT REAR PANEL

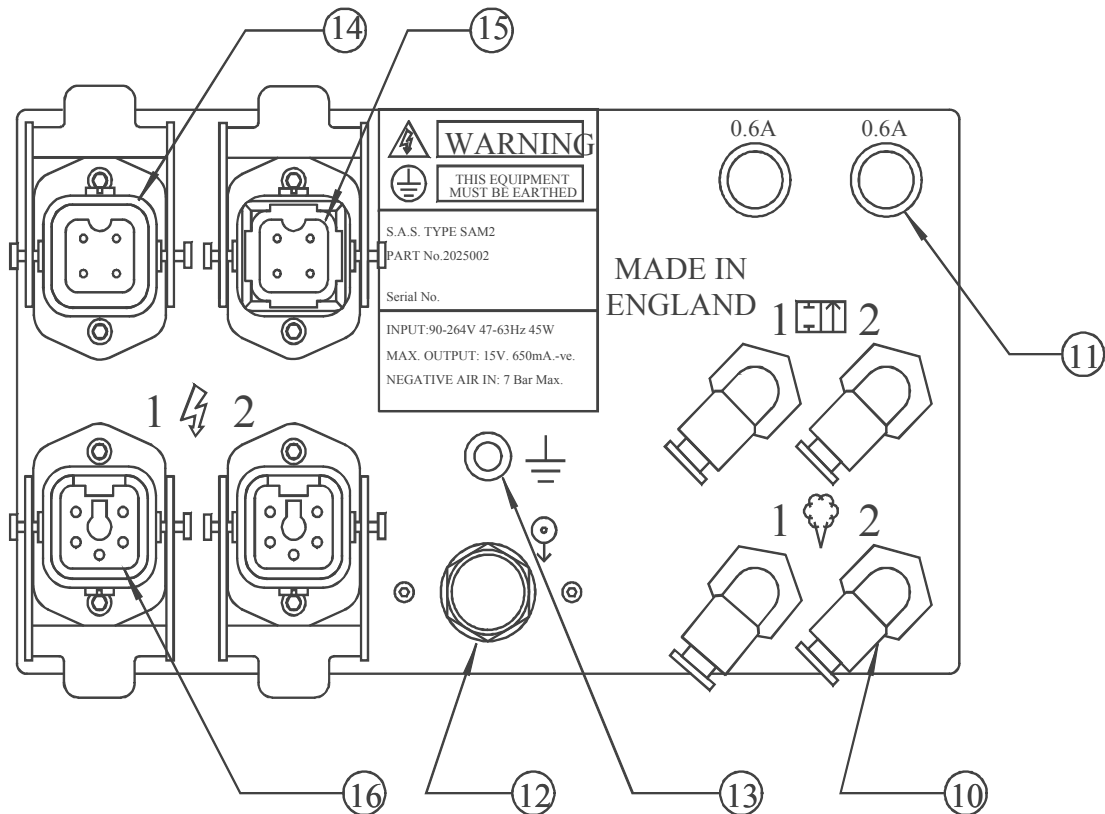

# SAS Manifold Inlet Assembly

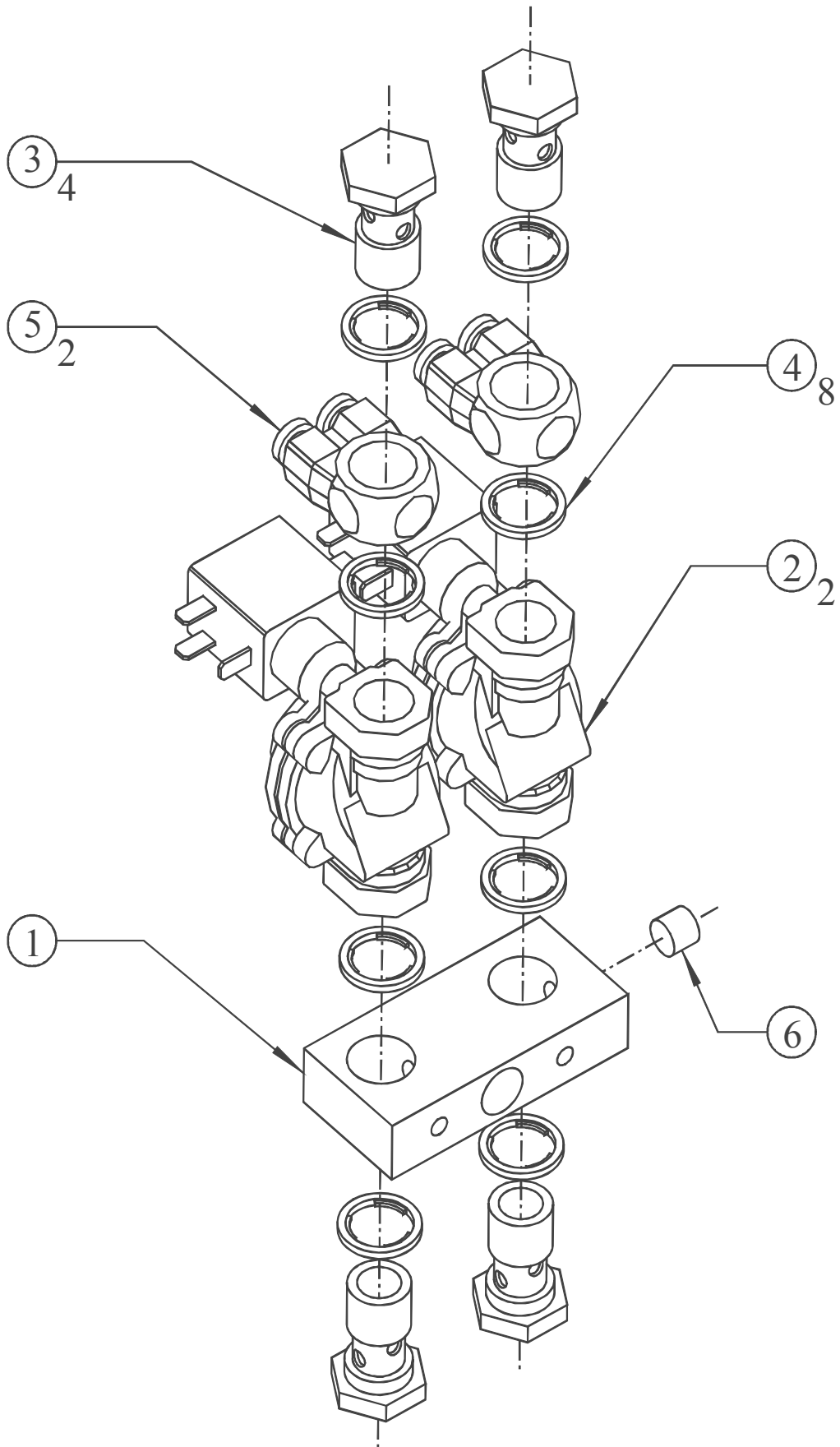

**SAS GCU General Assembly - Front**

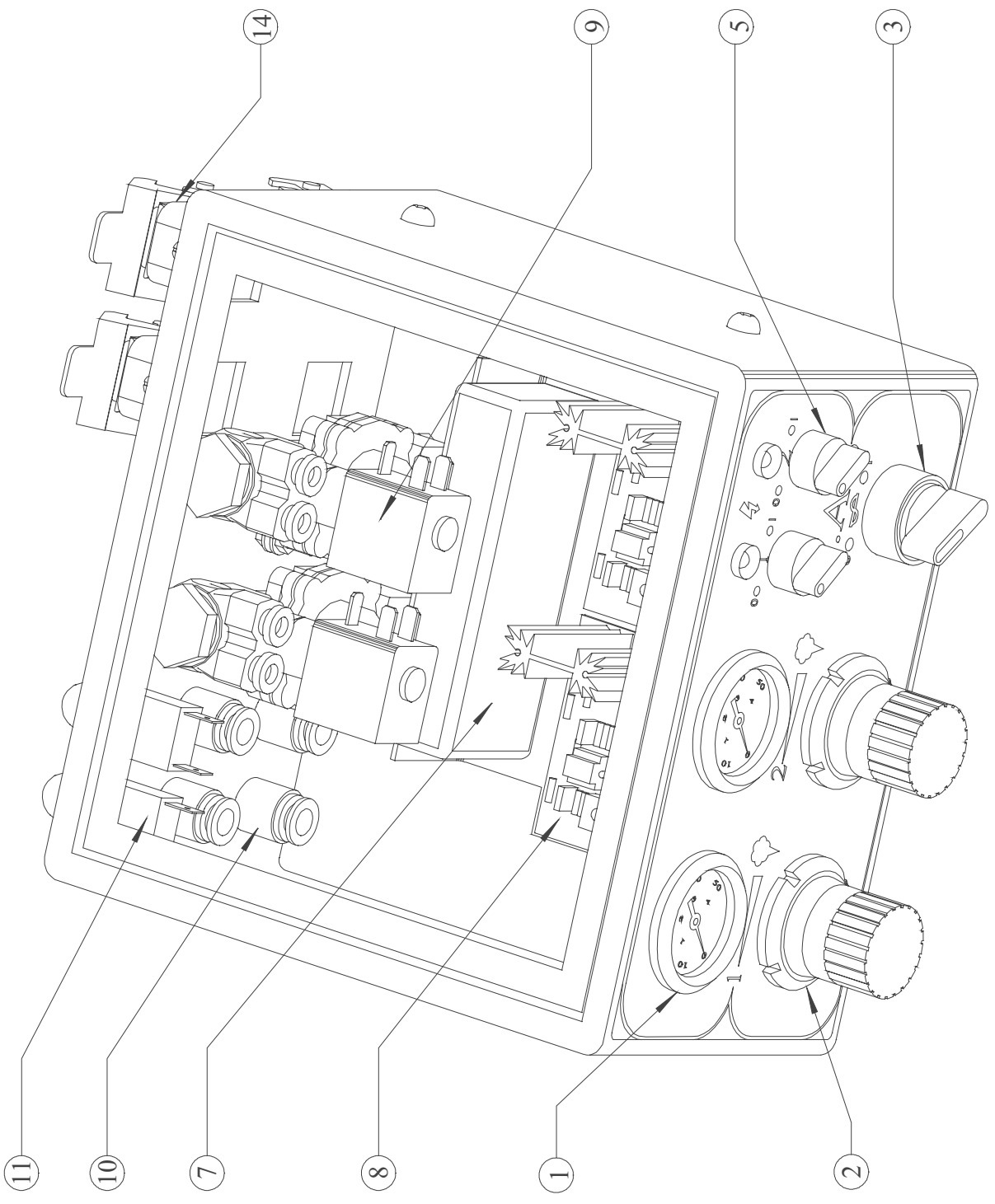

**SAS GCU General Assembly - Back**

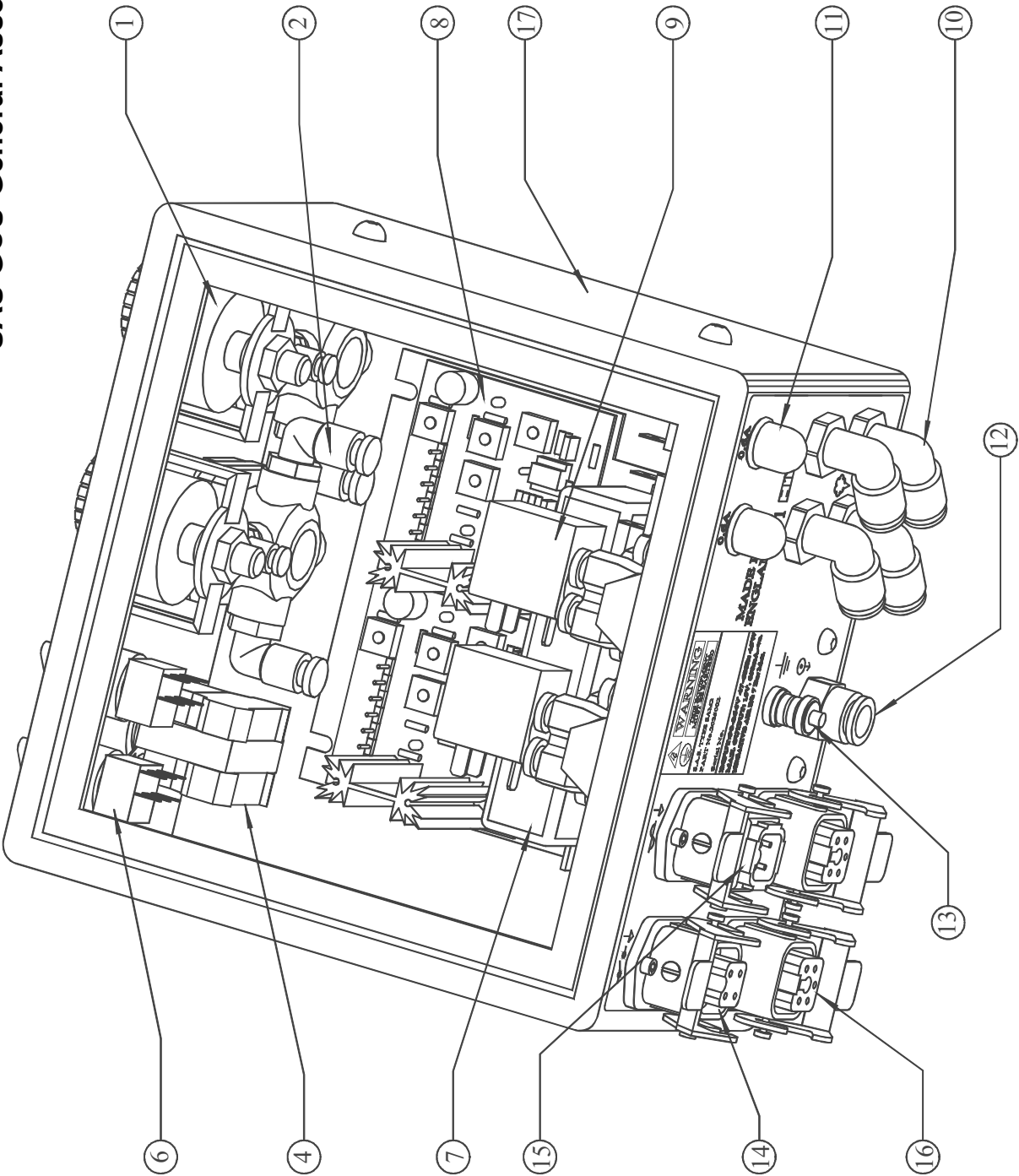

# SAS GCU Overall Dimensions

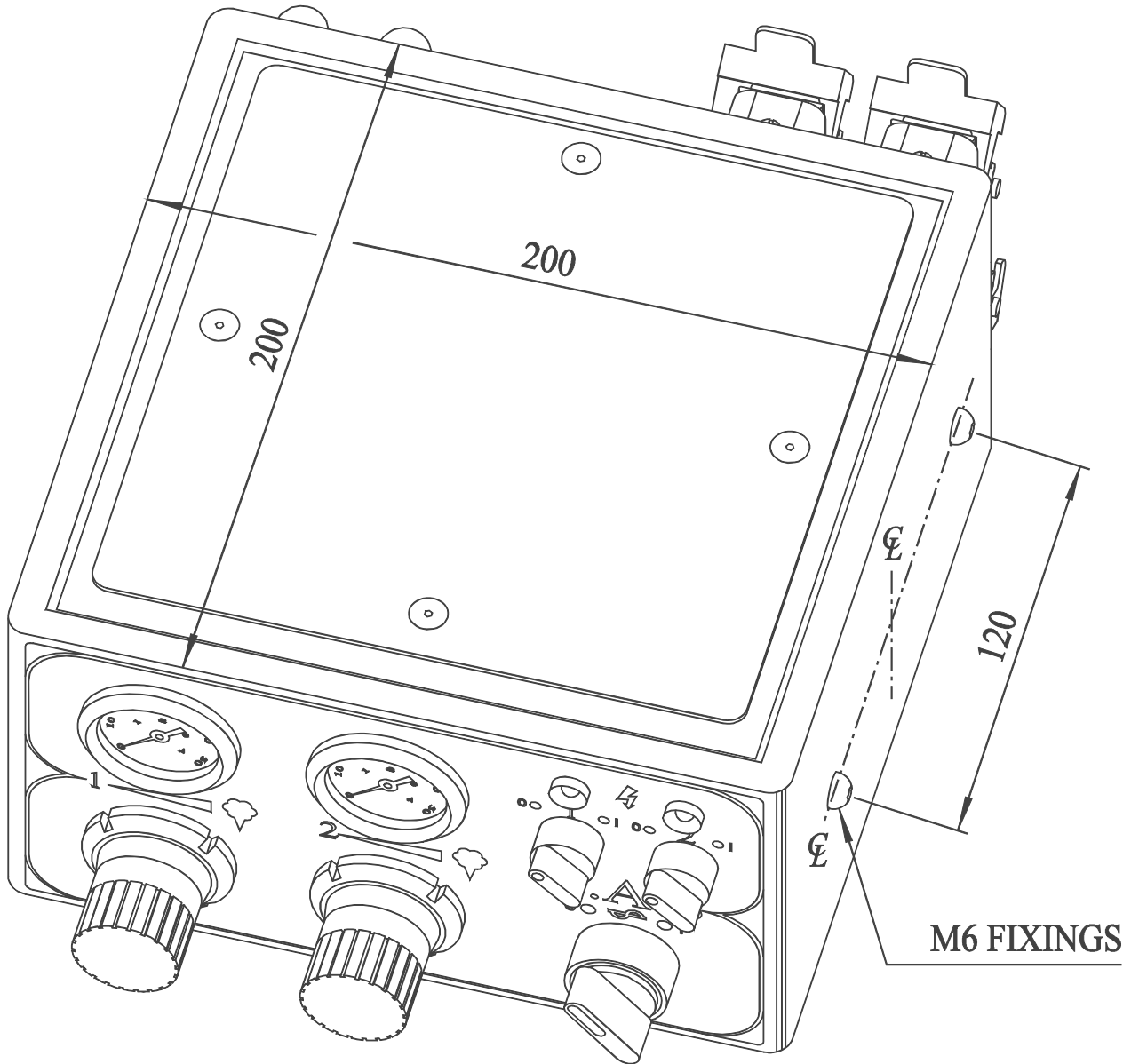

**Spice Application Systems  
Gun Control Unit General Assembly  
Part No. 2025030**

Item	Part No.	Description	Qty.
1	2020023	0-4 Pressure Gauge with Black Bezel	2
2	2025021	Pressure Regulator 4 Bar Assembly	2
3	9001797	Switch Front 22.5mm	1
4	9001798	Contact Assembly 22.5mm	1
5	9001799	Switch Front 16mm	2
6	9001800	Contact Assembly 16mm	2
7	9001768	Power Supply Unit SSL 40-7624	1
8	2025005	PCB Assembly	2
9	2025004	Inlet Manifold Assembly	2
10	9001758	Swivel Elbow, 8mm	4
11	9000016	Circuit Breaker, 0.6A	2
12	9001508	Straight, 1/4 BSPMT - 10mm OD Tube PI	1
13	9000021	Terminal, Earth Post	1
14	9000012	Connector Socket Insert 3 PIN + E	1 (2)
15	9000011	Connector Plug Insert, 3 PIN + E	1
16	9000013	Connector Socket Insert 4 PIN + E	2
17	2025010	SAS Case	1
18	2025012	SAS Lid *	1

\* Not shown on this illustration

**Spice Application Systems  
Inlet Manifold Assembly  
Part No. 2025004**

Item	Part No.	Description	Qty.
1	2025015	SAS Inlet Manifold	1
2	9000038	Valve, Solenoid, 2-2 3/8 BSP, 24V.DC	2
3	9001531	Banjo Bolt 3/8" BSP Single	4
4	9000042	Washer, Sealing, 3/8 BSP, Nylon	8
5	9001794	Banjo Body 8mm	2
6	9000034	Blank, 1/8 BSPMT, Hex SKT	1

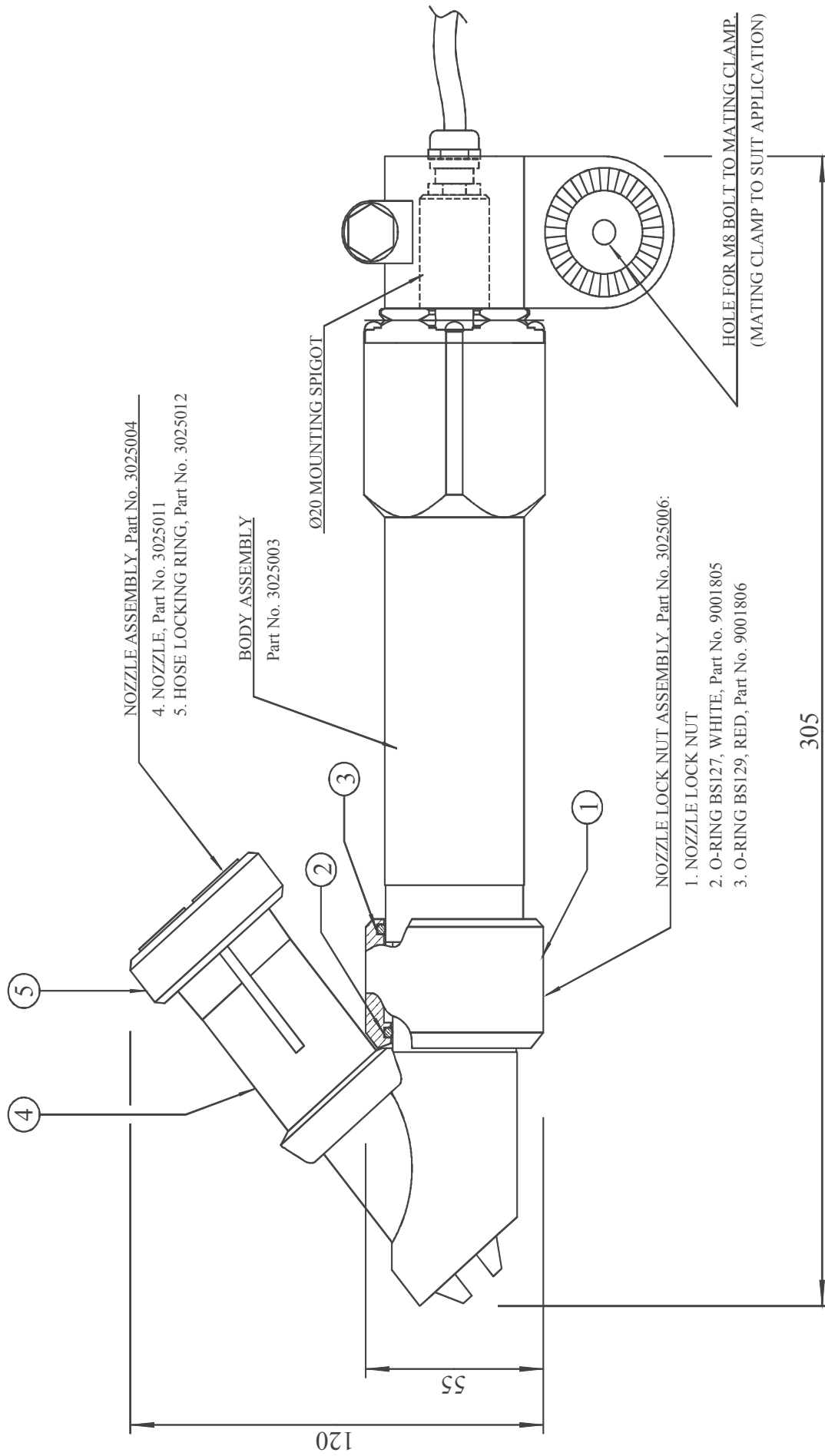

**IMPORTANT**

When fitting a plug to the mains lead it is essential that it contains an earthing/grounding contact and that this is connected. Under no circumstances should this equipment be connected to a mains supply which does not include an earthing/grounding wire and contacts. e.g.. 2 –Wire extension leads as used for some domestic equipment **MUST NOT BE USED.**

**NOTE:-** The cable colour coding used for the Control Unit and its supplied mains cable is as follows:-

<u>Pole</u>		<u>US/JAPAN</u>	<u>U.K.</u>
Live	<b>L</b>	Black	Brown
Neutral	<b>N</b>	White	Blue
Earth / Ground	<b>E</b>	Green	Green/Yellow

**For U.K. Equipment:**

The wire which is coloured *GREEN and YELLOW* must be connected to the terminal in the plug which is marked with the letter *E* or by the earth symbol, or coloured green or green and yellow. The wire which is coloured *BLUE* must be connected to the terminal which is marked with the letter *N* or coloured black. The wire which is coloured *BROWN* must be connected to the terminal which is marked with the letter *L* or coloured red.

**NOTE:-**

The terminals used in the mains connector on the control panel of the unit are:-

<u>POLE</u>	<u>PIN No.</u>
Live	Pin 1
Neutral	Pin 3
Earth / Ground	Pin E

The method of disconnection from the mains electrical supply is by removal of the mains lead plug from its respective supply socket.

**OPERATING PRINCIPLE**

The SAS control power supply transforms the 110/220 Vac into an adjustable voltage which can be set from 3.5 to 13 Vdc.

The generator at the spray head converts the 12 Vdc into 85 kV negative charge, the material being applied is drawn to the positively grounded product.

## INSTALLATION

For full and perfect performance the drum will require at least 6 horizontal flights and diameter of at least 0.750 mtr.

1. The product to be coated must be able to fully tumble and roll in front of the spray pattern. If it does not do so the electrostatic effect will not activate properly and will give poor quality finish to the product.
2. The appropriate distance between the spray head and the product to be coated to be about 20 - 45 cm / 8" - 18" (minimum distance is 15 cm / 6").
3. The spray heads needs to be positioned inside the drum facing the tumbling product at a 45° angle.
4. Attach the oil feed hose from the oil pump to the 10mm insert on the spray head, make sure it is pushed in firmly. Attach the spray nozzle to the electrostatic generating head, making sure the nozzle is seated in the groove on the head and tighten up the locking ring (Page 13 Item 1). Anti clockwise for locking, clockwise to un-lock.
5. The control unit must be located outside the flavouring drum.
6. **All metal parts, pumps, containers, conveyors (feeding in and out of the drum) and any other conductive article within 2mtrs/ 6ft - must be grounded.**
7. **The pump must be attached to earth**
8. Keep the spraying area clean. Remove all unnecessary metal components.
9. After fixing the the electrostatic generating head in place(The drum) Fix the black cable with plug attached to the back of the control attachment, to electrical plug maked "1" and lock into place. (Locking mechanism already attached to control) If using a twin head system attach both black cables, first to "1" and the second to "2" . [see control drawings under page 7 Item 16]
10. After fixing the electrostatic generating head in place(The drum) Fix the 8mm air line to the bottom air fittings on the back of the control to fitting "1" Push in firmly. If using a twin head system attach both 8mm air lines, first to bottom air fitting "1" and the second to bottom air fitting "2" . [see control drawings under page 7 Item 10] The other end of the air lines attached to the air fittings on the spray nozzles.
11. The two upper air fittings on the control are for blowing down the line for cleaning during spice change. The control is delivered with blank off plugs fitted. Remove a blank off plug and insert the 8mm air line (Push in firmly) which is attached to the blow down gun.
12. Plug into rear of control (Item.12) a10mm air line from the main air supply.(The air always has to be clean and dry. Fit a filter if necessary)

13. **When wiring up the mains supply the earth must be wired to the factory mains earth system**
14. Item 15 at the back of the control is for a remote trigger for tuning the unit to switch on and off with an existing production line. If not using, make sure the dust cap is fitted and locked into place.
15. Wire the earthing cables from the drum to the earthing point at the rear of the control. Item 13.
16. The drum must be earthed in 2 places. With the earthing contacts rubbing against the wall of the drum. The out going vibratory conveyor from the drum must always be earthed.

## **ATOMIZATION**

- 1 - The part to be coated must be connected to the ground continuously.
- 2 - Keep the spray unit perfectly clean.
- 3 - Do not use the equipment if there is an air leak in the hoses.
- 4 - Be sure that the product does not come closer than 15 cm / 6" and no further than 45cm/18" from the spray head.
- 5 - Before plugging in the power supply unit, be certain the electrostatic generating unit's spray nozzle is installed correctly. There are inserts on the spray nozzle which rest on the electrostatic generating head. (If fitted incorrectly the locking ring will not engage Item 1 Page 13)

## **OIL FLOW SYSTEM**

- 1 - Attach the 10mm oil feed hose into the spray nozzle.
- 2 - Position the spray head at about a 45 angle to the product
- 3 - The electrostatic generating head need not be moved for cleaning. The system is IP65
- 4 - The system must be set-up to freely transport the oil at the maximum line rate, i.e. set the air pressure at the electrode spray nozzle (0.25 - 2.0.bar) as if the plant is at maximum production.

## **START UP**

### **ELECTROSTATIC CIRCUIT**

- 1 - Connect the SAS control to its power source
- 2 - Supply the SAS control with clean dry compressed air (P = 4 bar / 58 psi)
- 3 - Turn the power-supply ON/OFF switch to the ON position (Item 3)
- 4 - Turn the voltage on/off switch on (Item 5)
  - ➔ The power supply emits a constant voltage at any given setting from 3,5 to 13 Vdc. This regulated voltage is transformed into high voltage within the generator barrel before being delivered to the spray head.

### **QUALITY ADJUSTMENT**

Adjust the spraying parameters ON THE FRONT OF THE CONTROL:

- Material flow rate (Pressure regulator Item 1 Page 9) Adjust by turning clock wise for more air anti-clockwise for less air. Push in to lock, pull out to unlock (Item 2 Page 9)
- Electrostatic effect : High voltage is on when the yellow light is glowing.
- Yellow light is dim : The spray heads are positioned too close to the product. Need to be adjusted further away.

All hoses and the generating head must remain clean

## CLEANING METHOD

The ON/OFF switches on the power supply and to the spray head must be OFF before starting cleaning operation.

Wait for 10 seconds before entering the drum

All metallic parts located within and around the spray head must be correctly connected to the ground. The floor must be electrically conductive and grounded.

Only apply a moderate amount of cleaning solution onto a clean soft cloth or bristle brush to clean the spray head and hoses.

Synthetic resins used in the fabrication of the electrostatic spray head can react with certain cleaning agents. Check with SAS .

**CAUTION** : avoid using the most toxic cleaning agents. Do not use chlorinates.

Dry the spray head carefully and thoroughly with air.

## PROCEDURE

1. Turn the power supply ON/OFF switch to OFF position.
2. Hose down the complete system in place (CIP). There is no need to remove the system for cleaning
3. Wash thoroughly and dry completely with compressed air before commencing production.

**Warning** : never switch ON the Electric power supply unit during the washing and cleaning operation.

Before switching ON the electrostatic effect :

- Install the spray nozzle onto the spray head.
- Connect the flexible oil tube to the spray nozzle
- Connect the 8mm air line to the spray nozzle
- Check the spray nozzle is locked in with the locking ring (Page 13 Item 1)

## SERVICING

- 1 - The electric power supply must be interrupted before any cleaning operation (**power supply unit switched OFF**).
- 2 - When shutting off the voltage, **wait for some 10 seconds** so that the electric charge has time to reach the ground.
- 3 - Do not soak or immerse the spray unit or any plastic parts in a solvent. This could result in damage and impair the safety circuits. If necessary, clean the plastic parts with a soft brush soaked in a soapy water solution after hosing down and then dry immediately.
- 4 - **Before disconnecting hoses, ensure that the circuit is no longer pressurized, the air is turned off, and that the electric current is also switched off.**
- 5 - After any repair - prior to turning on the power supply - **Always** make sure that the spray nozzle is correctly installed into the electrostatic generating head.
- 6 - Re-connect the three pin plug and cable assembly to the power source.
- 7 - Re-connect the ground wire to an earth connection.
- 8 - Re-connect low voltage cable between SAS control and electrostatic generator head

## EXTENDED SHUT-DOWN PERIOD

**1 - TURN THE ON/OFF SWITCH ON THE POWER SUPPLY TO THE OFF POSITION.**

- 2 - Carry out a complete flushing of the system. Carefully clean the spray head with a solution soaked rag or bristle brush.
- 3 - Dry the clean parts with compressed air. Be sure the air spray nozzle is clean.

**NEVER LEAVE ASSEMBLY AND SPRAY HEAD IMMERSSED IN CLEANING SOLUTION. ALWAYS STORE IN A DRY PLACE.**

**NEVER USE METAL TOOLS TO CLEAN THE SPRAY HEAD.**

## DAILY CARE

- 1 - spray head is kept clean,
- 2 - all hoses are not worn or crimped, all air and coating material connections are tight,
- 3 - all electrical cables are not broken or knotted
- 4 - All earthing wires on the in/outgoing vibratory trays and the drum are connected correctly

## TROUBLESHOOTING

### **Spitting Spray:**

1. **Insufficient air pressure:**
  - Turn up the air pressure
  - Check hoses for leaks and tighten fittings
2. **Oil vat empty:**
  - Fill the vat
3. **Pump not working correctly**
  - Engineers to check pump

### **No oil delivery:**

1. **Hose from pump to spray head blocked:**
  - Re-place the hose
2. **Pump not working:**
  - Turn on the pump
  - Engineers to check pump
3. **Pinched or restricted oil hose lines:**
  - Check and replace if necessary
4. **No oil in the vat**
  - Fill the vat with oil

### **Poor atomisation of oil:**

1. **Air nozzle obstructed or worn down:**
  - Clean nozzle or replace with new
2. **Low air pressure:**
  - Increase air pressure

### **Oil spraying, poor adhesion to product:**

1. **Voltage output too low:**
  - Adjust the spray head further away from the product
2. **Earthing not correct:**
  - Re-set the earth wiring and contacts
3. **Oil not suitable for electrostatic application:**
  - Contact oil supplier
4. **Electrostatics turned off:**
  - Turn on electrostatics at the control
5. **The low voltage cable not connected or is damaged**
  - Replace cable if needed. (This cable must be supplied by SAS)

### **Partial or missed coating of product:**

1. **Oil spray head incorrectly positioned in the drum:**
  - Set to correct position about 45° angle facing the tumbling product
2. **Insufficient oil output:**
  - Increase oil pump output
  - Re-fill oil Vat
3. **Flavouring drum speed:**
  - Increase or decrease drum speed
  - Raise or lower drum angle

**Misting in the air:**

1. ***Electrostatics are not turned on:***
  - Turn on at the control
2. ***The low voltage cable not connected or is damaged:***
  - Replace cable if needed. (This cable must be supplied by SAS)
3. ***Earthing not correct:***
  - Re-set the earth wiring and contacts
4. ***Air pressure too high:***
  - Turn down the pressure at the control

**Oil leaking from the back of the spray head**

1. ***Oil tube not fitted correctly:***
  - Re-insert oil tube into spray head, making sure the tube is pushed in all the way

**Operators are getting electric shocks:**

1. ***Earthing not connected:***
  - Re-set the earth wiring and contacts.
2. ***Operator not wearing conductive clothing;***
  - Purchase conductive foot gear, or conductive operator earthing straps

**Electric shocks from the intake and exit vibratory conveyors:**

1. ***No earthing on the vibratory trays:***
  - Fit earthing straps to both conveyors

**SPRAY NOZZLE :**

PART NO. SLURRY NOZZLE 02

## **STATIC ELECTRICITY TESTER. (S.E.T.)**

Instructions:

Always "self test" the tester (S.E.T) before you start. Do this by touching both ends simultaneously. The red light should illuminate indicating that the S.E.T. is functioning correctly.

Electrostatic test.

Turn on the electrostatic generating head.

Hold the S.E.T. with the screwdriver tip between the fingers. With the handle end pointing towards the generating head, about 1mtr. Away, move towards the electrode at the end of the electrostatic generator and you should see a strong red light illuminate, being at it strongest when you are within 400-500mm from the electrode.

**Always make sure you are holding onto an earthing point when doing this test, or you are wearing conductive shoes.**

If no red light appears refer to the main manual under Fault Finding:

# Remote Trigger Wiring Diagram

Remote  
Volt Free  
Contact

